



www.shinilent.com



SHINIL E&T
SHINIL E&T CO.,LTD

경기도 시흥시 시화벤처로 299 (3사 205호)
299, Sihwa venture-ro, Siheung-si, Gyeonggi-do, 15117, Rep. of KOREA
TEL:82-31-432-1495 FAX:82-31-432-1498
<http://www.shinilent.com> E-mail:shinilent@shinilent.com

THE WORLD BEST TECHNOLOGY AND QUALITY
SHINIL E&T

THE WORLD BEST TECHNOLOGY AND QUALITY

Good business partner SHINIL E&T

- 와이어 방전가공 공구 전문 생산 선두업체
- 초정밀 연마가공으로 깨끗하고 반짝이는 표면유지
- 특수가공된 다이아몬드를 사용하여 내구성 증대
- 숙련된 가공과 고도의 측정기술로 최소의 허용공차
- Leading company for precision tools for Wire EDM manufacturer.
- Achieved clean and bright surface with super finishing process
- Improvement of durability with applied specialized process diamond.
- Achieved minimum tolerance with the best technician and high-tech measurement technology

SINCE **1989**

1980

May, 1989 신일다이스 설립
Shinil Dies is founded

1990

Sep, 1997 경기도 유망중소기업 선정
Selected as Promising Small & Medium Sized Enterprise (Gyeonggi Province)

2000

July, 2000 신공장 이전 및 신일이엔티 (주) 법인 전환
Moved the new Factory and convert corporation to "Shinil E&T Co., Ltd."

July, 2008 기술혁신기업 선정
Selected as Innovation Business Company

Sep, 2008 부품 소재 전문기업 선정(지식경제부)
Selected as A Enterprise Specializing in Parts Materials

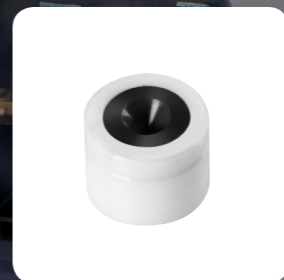

SUPPLY

성공을 공급합니다 WE ARE SUPPLYING SUCCESS

신일이엔티는 정밀가공 분야의 선두주자로 고객이 요구하는 바를 경쟁력 있는 가격과 믿음직한 서비스 정확한 납기로 부응합니다.

Shinil E&T, the leader of precision machining industry provides our customers tools made to their exact specifications at a competitive price, with reliable service and timely delivery.

2010~

- May, 2011 ISO14001 취득 및 기업연구소 설립
Achievement ISO 14001 and Established Research center
- June, 2012 벤처기업 지정
Certified as a Venture Enterprise
- June, 2013 ISO 9001 취득
Achievement ISO 9001
- July, 2014 신공장 신축 완료 및 이전
Completed the construction of New Factory and moved to new factory
- Jan, 2016 미국, 유럽, 일본 등에 WEDM 다이아몬드 가이드와 슈퍼드릴 가이드 수출
Start an export Diamond wire guide and super drill guide to U.S.A, Europe, Japan etc.
- July, 2017 다이아몬드와 스틸 접합 공정 기술 개발 및 특허 출원
Specialized technology for bonding process between diamond and steel is developed and patented.
- July, 2019 신규 개발 기술을 접목한 내구성이 향상된 신제품 출시
Release the new product with increased durability which applied new developed technology.
- July, 2020~ WEDM 다이아몬드 가이드 브랜드 별 전품목 생산 라인업 완료 및 전세계 20여 개국 전문 판매 대리점 구축
Complete whole item production line up for each WEDM brand and established distribution network in 20 countries of the world.

Leading WEDM manufacturers



FANUC

Sodick

+GF+
AgieCharmilles

JAPAX



ONA



AV&G

Seibu

brother At your side.

MITSUBISHI

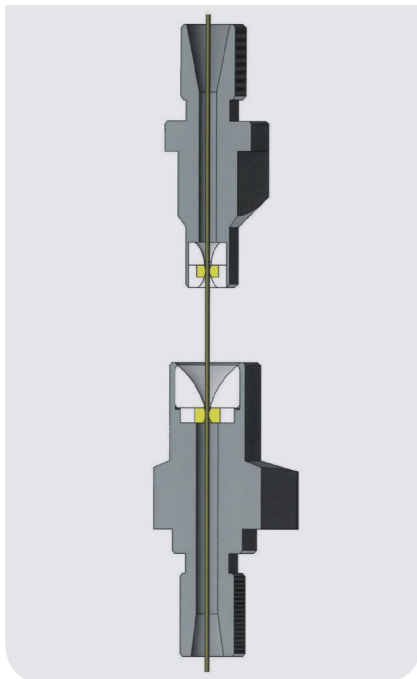

FANUC

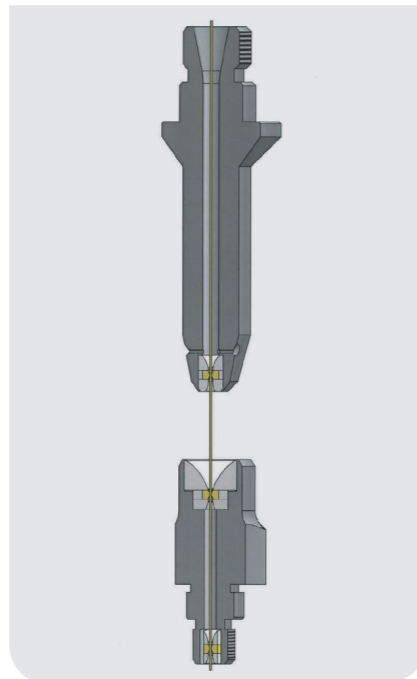

CHARMILE

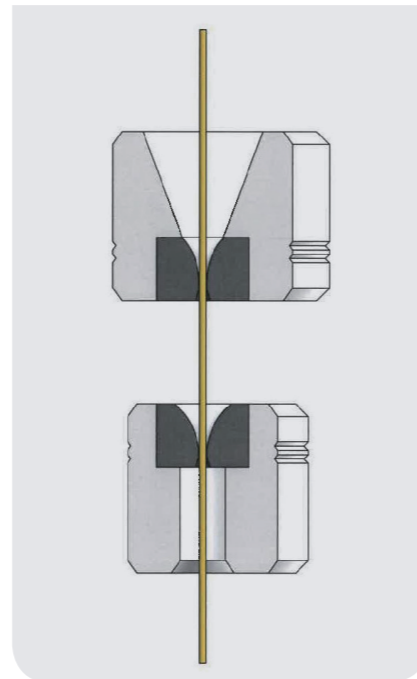

Diamond Wire Guide

for Wire-cut EDM

신일이엔티(주)에서 생산되는 EDM용 다이아몬드 와이어 가이드는 최상급 다이아몬드와 뉴세라믹스를 원자재로 사용하여 초정밀 자동화 설비와 엄격하고 공인된 품질관리 및 공정기술을 바탕으로 전 공정을 자체 가공함으로써 100% 고객 만족의 제품을 실현하고 있습니다.

The wire guide, a key part of the device for EDM, is located on the vertical stage. It is responsible for reducing wire vibrations and deflections by guiding the wire directly at the erosion zone, as well as for delivering dielectric to the erosion gap. SHINIL diamond wire guide for wire-cut EDM is made of using world's top synthetic diamond, and processing with a state-of-the-art machine and inspecting of quality assurance system, so we are confident that our products will meet the highest standard for customers.

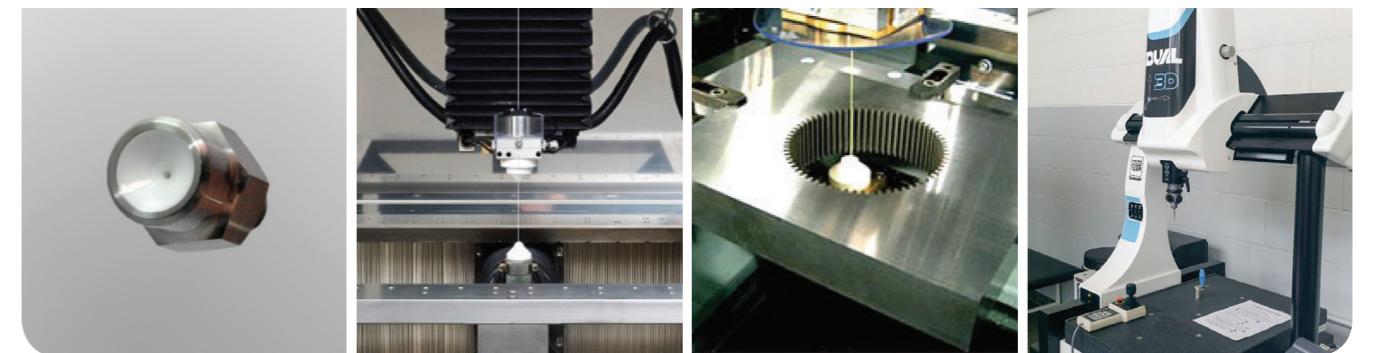
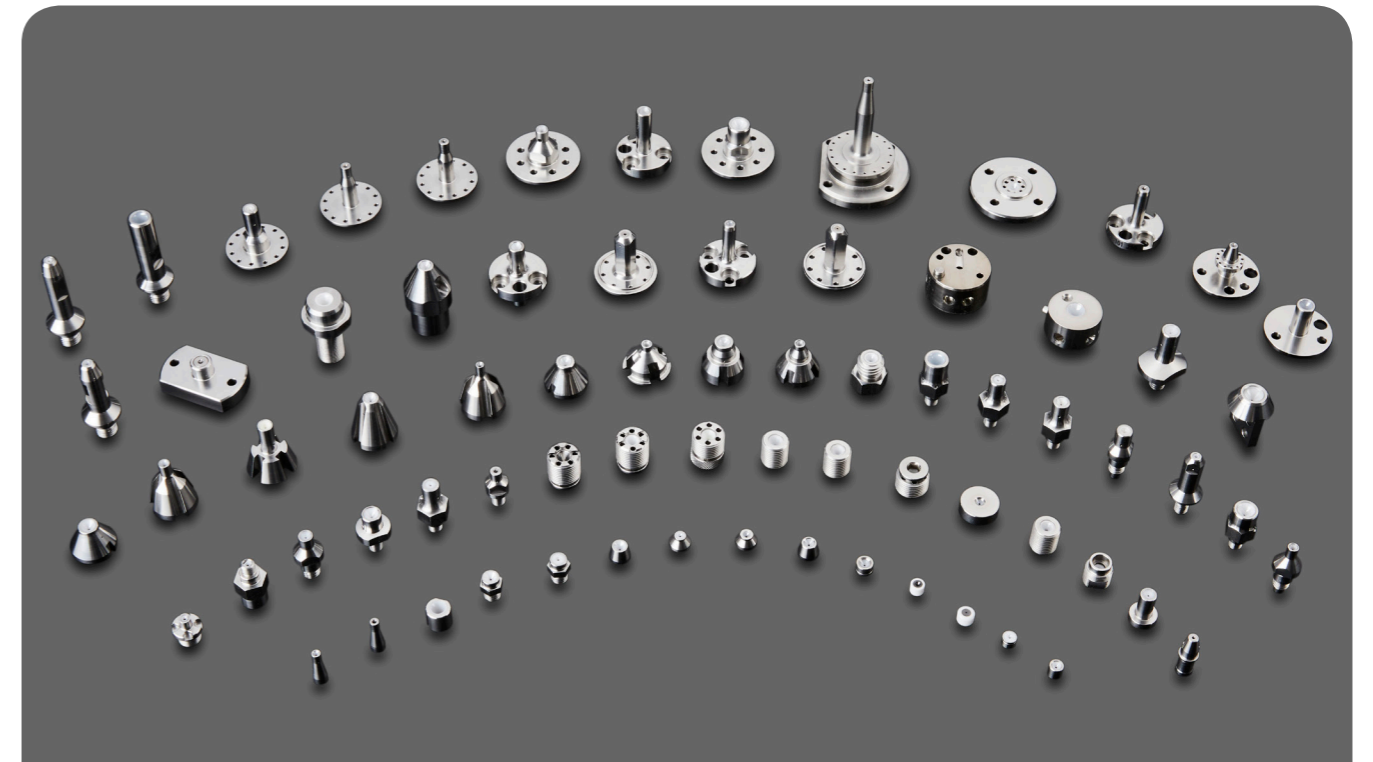

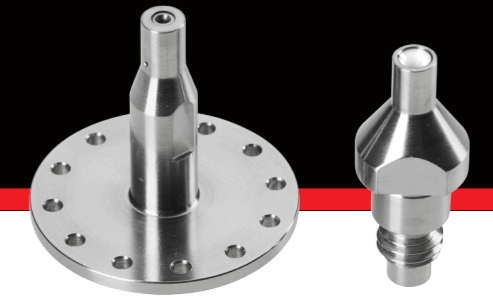



M102	Description	Size (Original No.)
	Diamond Wire Guide Lower DWC - F1, G, H, H' SK1	0.105 (X053C188G57) 0.110 (X053C188G52) 0.155 (X053C188G58) 0.160 (X053C188G53) 0.210 (X053C188G54) 0.260 (X053C188G55) 0.310 (X053C188G56)

M113	Description	Size (Original No.)
	Diamond Wire Guide (Set screw) Lower DWC-H1, HA, SA, SB, SZ AF1 Ceramic upper part	0.40 (X053C628G51)

M103	Description	Size (Original No.)
	Diamond Die Guide Upper & Lower DWC - H, H', H1, HA, C Manual	0.105 (X052B054G51) 0.155 (X052B054G52) 0.202 (X052B054G61) 0.205 (X052B054G53) 0.252 (X052B054G62) 0.255 (X052B054G54) 0.302 (X052B054G63) 0.305 (X052B054G55) 0.335 (X052B054G56)

M114	Description	Size (Original No.)
	Diamond Wire Guide Upper & Lower DWC - H, H', HA Manual SUS upper part	0.40 (X053C241G52)

M107-1	Description	Size (Original No.)
	Diamond Wire Guide Upper DWC - H1, HA, SA, SB, SZ AF1 Ceramic Coolant Hole	0.105 (X052B244G51) 0.155 (X052B240G51) 0.205 (X052B240G52) 0.255 (X052B240G53) 0.310 (X052B240G54)

M117	Description	Size (Original No.)
	Diamond Wire Guide Upper & Lower DWC-H1, HA, SA, SB, SZ, AF1	0.105 (X052B176G51) 0.155 (X052B176G52) 0.205 (X052B176G53) 0.255 (X052B176G54) 0.305 (X052B176G55)

M108	Description	Size (Original No.)
	Diamond Wire Guide (Set screw) Lower F, F1, G, N series Manual	0.40 (X054D162G54)

M120	Description	Size (Original No.)
	Diamond Wire Guide (Set screw) Upper DWC - H1, HA, SA, SB, SZ AF1	0.40 (X053C524G51)

M132	Description	Size (Original No.)
	Diamond Wire Guide Upper HA, SA, SB, SZ, SX, CX, FX, ZA, RA, FA DWC - BA / AT	0.105 (X053C834G51) 0.155 (X053C834G52) 0.205 (X053C834G53) 0.255 (X053C834G54) 0.305 (X053C834G56)

M155	Description	Size (Original No.)
	Guide "C" Upper & Lower Suitable for MV/NA Essence	0.60 (X085C096G53)

M133	Description	Size (Original No.)
	Diamond Wire Guide Lower HA, SA, SB, SZ, SX, CX, FX, QA, RA, FA AF2, AF3	0.105 (X052B243G63) 0.155 (X052B243G64) 0.205 (X052B243G61) 0.255 (X052B243G65) 0.305 (X052B243G62)

M160	Description	Size (Original No.)
	Diamond Wire Guide Upper MV - Series	0.105 (X052B627G66) 0.155 (X052B627G65) 0.205 (X052B627G64) 0.255 (X052B627G63) 0.305 (X052B627G62)

M135	Description	Size (Original No.)
	Diamond Sub Die "A" Upper DWC - CX, FX AF3	0.50 (X054D896G51)

M161	Description	Size (Original No.)
	Diamond Wire Guide Lower MV - Series	0.105 (X052B609G66) 0.155 (X052B609G65) 0.205 (X052B609G64) 0.255 (X052B609G63) 0.305 (X052B609G62)

M154	Description	Size (Original No.)
	Guide "UD" Upper & Lower Suitable for MV/NA Essence	0.60 (X085C079G53)





FANUC

F101	Description	Size (Original No.)
	Diamond Wire Guide Upper O, P, Q, R, T Series Manual	0.105 (A290-8021-X763) 0.155 (A290-8021-X764) 0.205 (A290-8021-X765) 0.255 (A290-8021-X766) 0.305 (A290-8021-X767)

F110	Description	Size (Original No.)
	Diamond Wire Guide Upper \varnothing - A, B, C, iA, iB, iC, iD Series without AWT	0.105 (A290-8101-X730) 0.155 (A290-8101-X732) 0.205 (A290-8101-X733) 0.255 (A290-8101-X734) 0.305 (A290-8101-X735)

F102	Description	Size (Original No.)
	Diamond Wire Guide Lower O, P, Q, R, T, W Series Manual	0.105 (A290-8021-X773) 0.155 (A290-8021-X774) 0.205 (A290-8021-X775) 0.255 (A290-8021-X776) 0.305 (A290-8021-X777)

F111	Description	Size (Original No.)
	Diamond Wire Guide Lower \varnothing - A, B, C, iA, iB, Series without - AWT	0.105 (A290-8101-X740) 0.155 (A290-8101-X742) 0.205 (A290-8101-X743) 0.255 (A290-8101-X744) 0.305 (A290-8101-X745)

F103	Description	Size (Original No.)
	Diamond Die Guide Upper V, T Series AWF	0.105 (A290-8032-X773) 0.155 (A290-8032-X774) 0.205 (A290-8032-X775) 0.255 (A290-8032-X776) 0.305 (A290-8032-X777)

F112	Description	Size (Original No.)
	Diamond Wire Guide Upper \varnothing - A, B, C, iA, iB, iC, iD, iE, C400iA Series AWT	0.105 (A290-8092-X702) 0.155 (A290-8092-X704) 0.205 (A290-8092-X705) 0.255 (A290-8092-X706) 0.305 (A290-8092-X707)

F104	Description	Size (Original No.)
	Diamond Wire Guide Lower V, T, W Series AWF	0.205 (A290-8032-X735) 0.255 (A290-8032-X736) 0.305 (A290-8032-X737)

F113	Description	Size (Original No.)
	Diamond Wire Guide Lower \varnothing - A, B, C, iA, iB, iC, iD Series AWF	0.105 (A290-8110(8092)-X712) 0.155 (A290-8110(8092)-X714) 0.205 (A290-8110(8092)-X715) 0.255 (A290-8110(8092)-X716) 0.305 (A290-8110(8092)-X717)

F113-1	Description	Size (Original No.)
	Diamond Wire Guide Lower \varnothing - Id2.xiE series Double Diamonds	0.155 (A290-8119-Y714) 0.205 (A290-8119-Y715) 0.255 (A290-8119-Y716) 0.305 (A290-8119-Y717)

F112T	Description	Size (Original No.)
	Diamond Wire Guide Upper \varnothing - A, B, C, iA, iB, iC, iD Series AWF 45° Taper	0.105 (A290-8104-X702) 0.155 (A290-8104-X704) 0.205 (A290-8104-X705) 0.255 (A290-8104-X706) 0.305 (A290-8104-X707)

F114	Description	Size (Original No.)
	Diamond Wire Guide Upper \varnothing - A, B, C, iA, iB, iC, iD Series AWF High Accuracy Type	0.102 (A290-8104-Y702) 0.152 (A290-8104-Y704) 0.202 (A290-8104-Y705) 0.252 (A290-8104-Y706) 0.302 (A290-8104-Y707)

F113T	Description	Size (Original No.)
	Diamond Wire Guide Lower \varnothing - A, B, C, iA, iB, iC, iD Series AWF 45° Taper	0.105 (A290-8110(8104)-Z712) 0.155 (A290-8110(8104)-Z714) 0.205 (A290-8110(8104)-Z715) 0.255 (A290-8110(8104)-Z716) 0.305 (A290-8110(8104)-Z717)

F115	Description	Size (Original No.)
	Diamond Wire Guide Lower \varnothing - A, B, C, D, iA, iB, iC, iD Series AWF High Accuracy Type	0.102 (A290-8104-Y712) 0.152 (A290-8104-Y714) 0.202 (A290-8104(8110)-Y715) 0.252 (A290-8104(8110)-Y716) 0.302 (A290-8104(8110)-Y717)

F114T	Description	Size (Original No.)
	Diamond Wire Guide Upper \varnothing - iC, iCP, iD Series AWF 45° Taper Finishing	0.205 (A290-8112-Z705) 0.255 (A290-8112-Z706)

F115-1	Description	Size (Original No.)
	Diamond Wire Guide Lower \varnothing - OiC, OiD, 1iD Series AWF Double Diamond for High Precision	0.102 (A290-8119-Y703) 0.152 (A290-8119-Y704) 0.202 (A290-8119-Y705) 0.252 (A290-8119-Y706) (A290-8119-Y716) 0.302 (A290-8119-Y707)

F115T	Description	Size (Original No.)
	Diamond Wire Guide Lower \varnothing - iC, iCP, iD Series AWF AWF 45° Taper Finishing	0.210 (A290-8112-Z715) 0.260 (A290-8112-Z716)



Sodick

S102	Description	Size (Original No.)
	Diamond Wire Guide Upper & Lower G, EPOC, AW, BF, PGW150, AP(150W/150) KM-1/KM-3/83/84/ 85-2/85-3 Type	0.105 (3080236)
		0.110 (3080237)
		0.120 (3080238)
		0.155 (3080512)
		0.160 (3080240)
		0.170 (3080241)
		0.205 (3080243)
		0.210 (3080244)
		0.220 (3080245)
		0.255 (3080247)
		0.260 (3080248)
		0.270 (3080249)
		0.305 (3087704)
		0.310 (3080250)
		0.320 (3080251)

S103	Description	Size (Original No.)
	Diamond Wire Guide Upper & Lower JL, EPOC, AW, BF, PGW, EXC, AP, A, AQ, AD, AG 87-3/30-3/30-5/FJ Type	0.110 (3080998)
		0.120 (3081015)
		0.160 (3080999)
		0.170 (3081016)
		0.210 (3081000)
		0.220 (3080982)
		0.255 (3081423)
		0.260 (3080990)
		0.270 (3081017)
		0.310 (3080991)
		0.320 (3081018)

S103-1	Description	Size (Original No.)
	Diamond Wire Guide Lower AQ, A, EPOC, AP, BF, JL EXC100, EXC100S, PGW200 Without AWT	0.205 (J03644A)
		0.210 (J03645A)
		0.220 (J03646A)
		0.255 (J03647A)
		0.260 (J03648A)
		0.270 (J03649A)

S104	Description	Size (Original No.)
	Diamond Wire Guide Upper & Lower JL, EPOC, AW, BF, PGW, EXC, AP, A, AQ, AD, AG, KM-1/KM- 3/83/84 85-2/85-3 TYPE Super Jet AWT/97AWT/ 85AWT/90AWT/FJ-AWT	0.110 (3080210)
		0.120 (3080211)
		0.160 (3080213)
		0.170 (3080214)
		0.210 (3080219)
		0.220 (3080220)
		0.260 (3080223)
		0.270 (3080224)
		0.310 (3080225)
		0.320 (3080226)

S109	Description	Size (Original No.)
	Diamond Wire Guide Upper SJ-AWT (Option 0) AQ-1U(S) AQ, AD, AG Single Diamond	0.110 (118762A)
		0.155 (118745A)
		0.160 (118758A)
		0.205 (118725)
		0.210 (118759A)
		0.255 (118726)
		0.260 (118760A)
		0.310 (118727)

S115	Description	Size (Original No.)
	Diamond Wire Guide Upper AQ, AD, AG Fixed Jet AWT Double Diamonds Ceramic Coolant Hole	0.105 (J17101A)
		0.110 (J17102A)
		0.155 (J17104A)
		0.160 (J17105A)
		0.205 (J17107S)
		0.210 (J17108S)
		0.255 (J17110A)
		0.260 (J17111A)
		0.310 (J17114A)

CHMER

CH101	Description	Size (Original No.)
	Diamond Wire Guide Upper & Lower CW - 340, 430, 530, 640, 750, 850, 530C Manual	0.105
		0.155
		0.205 (3140001)
		0.255
		0.305
		0.310

CH102	Description	Size (Original No.)
	Diamond Wire Guide Upper & Lower CW - 340, 430, 530, 640, 750, 850, 530C AWT	0.105
		0.155
		0.205 (3W53A92A)
		0.255
		0.305
		0.310

+GF+ AgieCharmilles

435.604	Description
	Diamond Wire Guide Lower AV Evolution, AC Classic (Included 326.834)

417.984	Description
	Diamond Wire Guide Upper AV Evolution, AC Classic (Included 326.834)

C101	Description	Size (Original No.)
	Diamond Wire Guide Upper ROBOFIL Series Cut20, Cut30 Ceramic Housing	0.07 (200431021)
		0.10 (100431022)
		0.15 (200431114)
		0.20 (200431112)
		0.25 (100432511)
		0.30 (200432512)

C102	Description	Size (Original No.)
	Diamond Wire Guide Lower ROBOFIL Series Cut20, Cut30 Ceramic Housing	0.07 (200431025)
		0.10 (100431027)
		0.15 (200431124)
		0.20 (200431122)
		0.25 (100430586)
		0.30 (200432814)

C103	Description	Size (Original No.)
	Diamond Wire Guide Upper ROBOFIL Series Cut20, Cut30 Stainless Steel Housing	0.10 (200431022)
		0.15 (200431114)
		0.20 (200431112)
		0.25 (100432511)
		0.30 (200432512)

C104	Description	Size (Original No.)
	Diamond Wire Guide Lower ROBOFIL Series Cut20, Cut30 Stainless Steel Housing	0.07 (200431026)
		0.10 (100431027)
		0.15 (200431124)
		0.20 (200431122)
		0.25 (100430586)
		0.30 (200432814)

brother® At your side.

B102	Description	Size (Original No.)
	Diamond Wire Guide Upper HS-3100, 3600 AWF	0.205 (632989000)
		0.255 (632990000)
		0.305 (632991000)

B103	Description	Size (Original No.)
	Diamond Wire Guide Lower HS-3100, 3600 AWF	0.105 (632984000)
		0.155 (632985000)
		0.205 (632986000)
		0.255 (632987000)
		0.305 (632988000)





SPM132	Description	Size (Original No.)
	Diamond Wire Guide Upper SP430S, 430P, 640P, 850P	0.105 0.155 0.205 (P74-U860) 0.255 0.305 0.310

SPM110	Description	Size (Original No.)
	Diamond Sub Dies EZ Series	0.40 (P74-U891)

SPM133	Description	Size (Original No.)
	Diamond Wire Guide Lower SP430S, 430P, 640P, 850P	0.105 0.155 0.205 (P74-L950) 0.255 0.305 0.310

SPM111	Description	Size (Original No.)
	Die Holder for PFC EZ Series	0.40 (P74-U850)

SPM108	Description	Size (Original No.)
	Diamond Auxiliary Guide Upper EZ Series	0.40 (P74-U840)

SPM134	Description	Size (Original No.)
	Diamond Wire Guide Upper Big Taper	0.105 0.155 0.205 (P74-U862) 0.255 0.305 0.310

SPM109	Description	Size (Original No.)
	Diamond Auxiliary Guide Lower EZ Series	0.40 (P74-L980)

SPM135	Description	Size (Original No.)
	Diamond Wire Guide Lower Big Taper	0.105 0.155 0.205 (P74-L952) 0.255 0.305 0.310

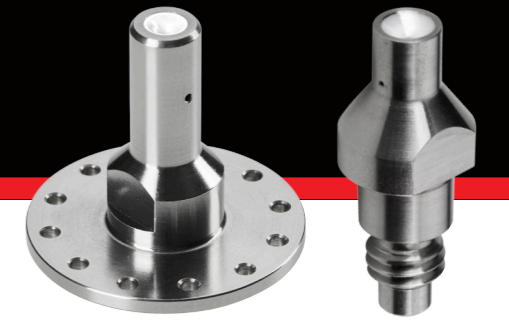

O101	Description	Size (Original No.)
	Diamond Wire Guide Upper Prima Series AWF	0.105 (AE6999006) 0.155 (AE6999009) 0.205 (AE6999011) 0.255 (AE6999004) 0.305 (AE6999008)

O103	Description	Size (Original No.)
	Diamond Wire Guide Upper Prima Series AWF	0.205 (E69200037R00) 0.255 (E69200039R00) 0.305 (E69200041R00)

O102	Description	Size (Original No.)
	Diamond Wire Guide Lower Prima Series AWF	0.105 (AE6999005) 0.155 (AE6999101) 0.205 (AE6999012) 0.255 (AE6999003) 0.305 (AE6999007)

O104	Description	Size (Original No.)
	Diamond Wire Guide Lower Prima Series AWF	0.205 (E69200038R00) 0.255 (E69200040R00) 0.305 (E69200042R00)



SE111	Description	Size (Original No.)
	Diamond Wire Guide Upper & Lower EW - F, K, K1, K2 Manual / AWF	0.210 (4440400-7) 0.260 (4440400-9) 0.310 (4440400-8)

SE114	Description	Size (Original No.)
	Diamond Wire Guide Upper & Lower EW-A5S, A7S, C5S3 AWF	0.210 0.260 (3438115) 0.310

SE115	Description	Size (Original No.)
	Diamond Wire Guide (LD Die) Upper & Lower EW-A5S, A7S, C5S3 AWF	0.210 0.260 (4461551) 0.310

SE116	Description	Size (Original No.)
	Diamond Wire Guide (LLD Die) Upper & Lower EW-A5S, A7S, C5S3 AWF	0.210 0.260 (4458910) 0.310





AV&G

AV102	Description	Size (Original No.)
	Diamond Wire Guide	0.105 0.155 0.205 0.255 0.305

K80-N240(7)	Description	Size (Original No.)
	Diamond Wire Guide Upper	0.170 0.270 0.320

AV132	Description	Size (Original No.)
	Diamond Die Guide Upper	0.105 0.155 0.205 0.255 0.305

K80-M040(3)	Description	Size (Original No.)
	Diamond Wire Guide Lower	0.170 0.270 0.320

AV133	Description	Size (Original No.)
	Diamond Wire Guide Lower	0.105 0.155 0.205 0.255 0.305

AV117	Description	Size (Original No.)
	Diamond Wire Guide Lower	0.105 0.155 0.205 0.255 0.305

HITACHI

H101	Description	Size (Original No.)
	Diamond Wire Guide Upper Hi-Cut 203,304, 345 460 Q Series Manual	0.205 0.255 0.305 (Q1846(C206))

H102	Description	Size (Original No.)
	Diamond Wire Guide Lower Hi-Cut 203,304, 345 460 Q Series Manual	0.205 0.255 0.305 (Q1848(C207))

JAPAX

J101	Description	Size (Original No.)
	Diamond Wire Guide Upper LS-S, X, LUX, LV, LXE, LXR, LDM, ELVY Manual	0.205 (SSZ1106) 0.255 (SSZ1107) 0.305 (SSZ1108)

J102	Description	Size (Original No.)
	Diamond Wire Guide Lower LS-S, X, LUX, LV, LXE, LXR, LDM, ELVY Manual	0.205 (SSZ2106) 0.255 (SSZ2107) 0.305 (SSZ2108)

MAKINO

A103	Description	Size (Original No.)
	Diamond Wire Guide Upper DUO43, 53, W32FB, 253FB	0.105 (23EC085A207) 0.155 (23EC085A222) 0.205 (23EC085A209) 0.255 (23EC085A212) 0.305 (23EC085A215)

A104	Description	Size (Original No.)
	Diamond Wire Guide Lower DUO43, 53, W32FB, 253FB	0.105 (20EC090A213) 0.155 (20EC090A201) 0.205 (20EC090A203) 0.255 (20EC090A207) 0.305 (20EC090A211)

A105	Description	Size (Original No.)
	Diamond Die Guide Lower	0.105 (33EC095A104) 0.155 (33EC095A105) 0.205 (33EC095A106) 0.255 (33EC095A107) 0.305 (33EC095A108)





JET NOZZLE

F128	Description	Size (Original No.)
	Upper Sub-Guide ø - A, B, C, iA, iB, iC, iD, iE Series AWF <i>Only Ceramic Inserted</i>	0.35 (A290-8104-X620) 0.55 (A290-8102-X620)

F125	Description	Size (Original No.)
	Jet Nozzle ø - A, B, C, iA, iB, iC, iD, iE Series AWF <i>Only Ceramic Inserted</i>	0.50 (A290-8102-Y757) 0.80 (A290-8102-Y755) 1.00 (A290-8102-Y761) 1.50 (A290-8102-Y756) 1.80 (A290-8103-Y754)

M129	Description	Size (Original No.)
	Jet nozzle HS, SA, SB, SZ, SX, CX, FX, QA, RA, FA, NA series	0.50(X054D826H02) 0.75(X052D826H07) 1.00(X052D826H04) 1.50(X052D826H01)

A120	Description	Size (Original No.)
	Jet Nozzle W32FB, W53FB, DU0043, DUI064, U Series <i>New Version</i>	0.50 (23EC085A217) 0.70 (23EC085A218) 1.00 (23EC085A219) 1.20 (23EC085A202) 1.50 (23EC085A220)

DRILL GUIDE

A TYPE	Description	Hole size
	Super Drill Guide Upper & Lower Ceramic Insert	0.10-0.14 0.15-0.29

B TYPE	Description	Hole size
	Super Drill Guide Upper & Lower Ceramic Insert	0.30 ~ 3.50

C TYPE	Description	Hole size
	Super Drill Guide Lower Ceramic Insert	4.00 4.50 5.00 5.50 6.00

SPECIAL TYPE

DIAMOND WIRE GUIDE



JET NOZZLE



SUPER DRILL GUIDE



EDM WEAR PART



생산현장

FACILITIES STATUS

당사는 풍부한 경험과 기술력을 바탕으로 고객이 원하는 바를 분석하여 최적화 된 제품을 설계하며 품질을 향상시키기 위한 내구성 시험과 효율 시험을 통해 최고의 제품을 개발합니다.

We are designing optimized products by analyzing what our customer needs based on our full experience and technology, also developing the best products through Endurance test, Efficiency tests to improve quality.







인증 현황

CERTIFICATION STATUS

시장 검증을 통해 입증된 경험과 기술력을 바탕으로 고객의 니즈를 만족하는 제품 실현을 위해 지속적인 연구개발에 집중하고 있으며 최신동향을 반영한 기술혁신과 첨단기술을 선도하는 기업이 되도록 최선의 노력을 다하고 있습니다.

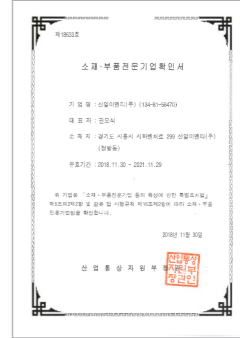
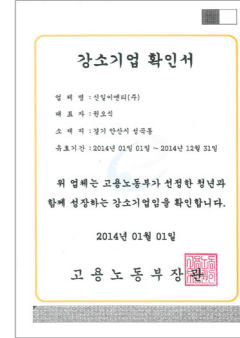
We are focusing on continuous development to fulfill what our customer needs based on proved experienced through market verification and technology, trying our best to become a company leading technology innovation and latest technology.

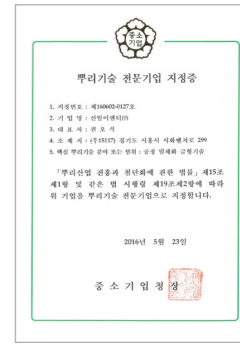
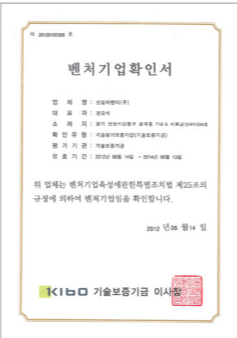
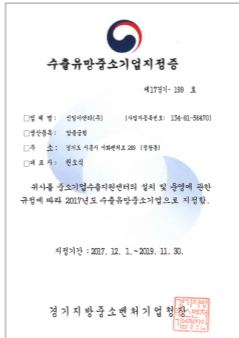
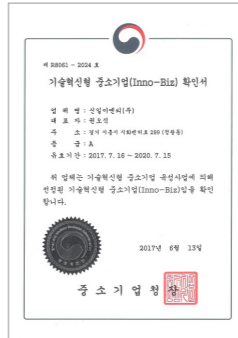
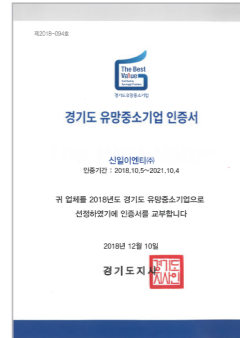
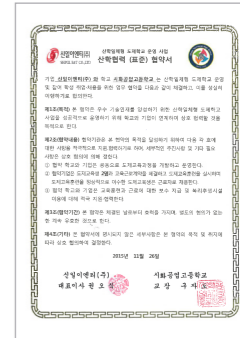
				
특허증 Patent certificate	특허증 Patent certificate	기업부설연구소 R&D Center	부품소재전문기업 Parts Specialized Company	강소기업 Small Hidden Company
				
ISO9001	ISO14001	부리기술평문기업지정증 Certified specialist by KTC		
				
벤처기업확인서 Venture Company	수출유망중소기업인증서 Promising Export SME Confirmation	이노비즈 INNO-BIZ	유망중소기업인증서 Promising SME in Gyeonggi-Do	산학협력표준협약서 Agreement for industry-Academy cooperation